

The Silica Tetrahedron and the Architecture of Silicate Minerals

With oxygen and silicon comprising approximately 85% of the atoms in Earth's crust, most minerals in the crust include these two elements, and form the class of minerals called **silicates**. The basic building block of all silicate minerals is the silica tetrahedron, in which one silicon ion bonds with four oxygen ions. This arrangement of ions (coordination number of 4) is dictated by the ratio of ionic radii. It allows the silicon ion to fit snugly in the middle of the oxygen ions, but results in a charge imbalance. The resulting complex ion is SiO_4^{4-} .

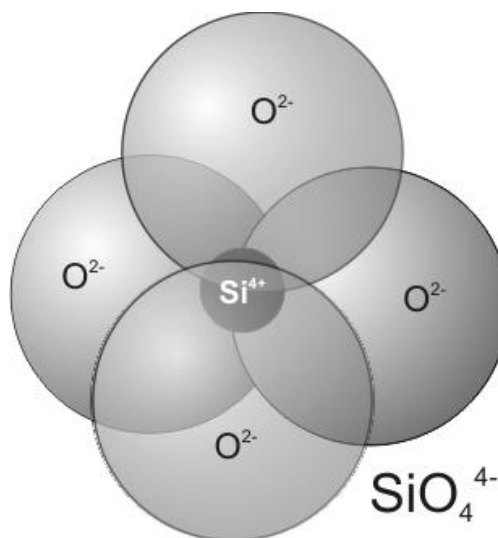

Minerals have a neutral charge that is achieved through bonding of silica tetrahedra with cations and/or with additional silica tetrahedra. The arrangement of tetrahedra in a silicate mineral provides the structure around which the mineral grows, thereby controlling the preferred form of the mineral as it grows. In addition, the Si-O bond is stronger than all other bonds in silicate minerals, and therefore is the hardest to break. Thus the arrangement of the silica tetrahedra also control the way in which minerals break.

Silicate structures control habit, cleavage, and fracture of minerals. However, as three-dimensional forms, silicate structures can be difficult to visualize and understand. Through modeling of silicate structures with paper tetrahedra, it is the primary objective of this activity to have you be able to describe how each silicate structure (isolated tetrahedra, rings, single chains, double chains, sheets, and networks) leads to a characteristic set of habits and cleavage that are commonly exhibited by each class of silicate minerals.

Break into eight groups, with two groups sitting together at each table. Note your table number (1 through 4). Have each group gather the following supplies:

- One tetrahedron template sheet per person
- Two 12-inch pipe cleaners per person
- One pair of scissors per person
- One roll of Scotch tape per group
- One bottle of glue per group
- Six completed tetrahedra per group
- Six beads per group

PART 1: Constructing Tetrahedron Models (Optional)

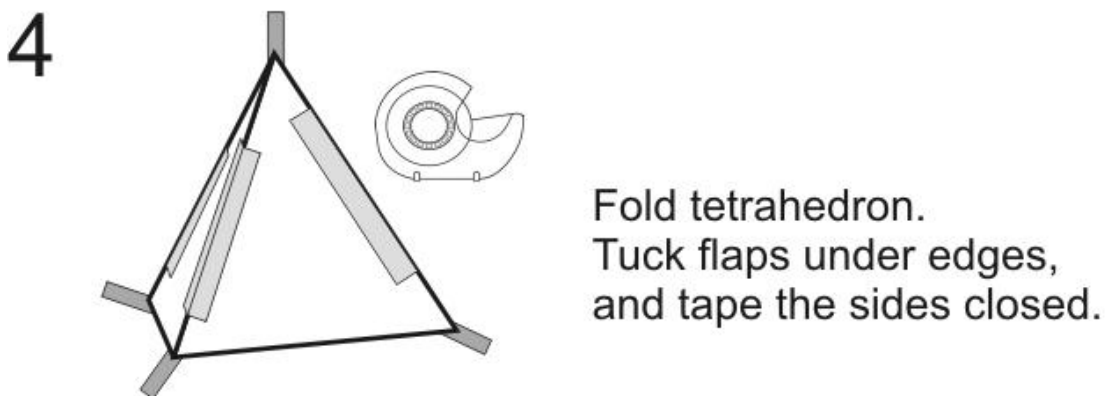
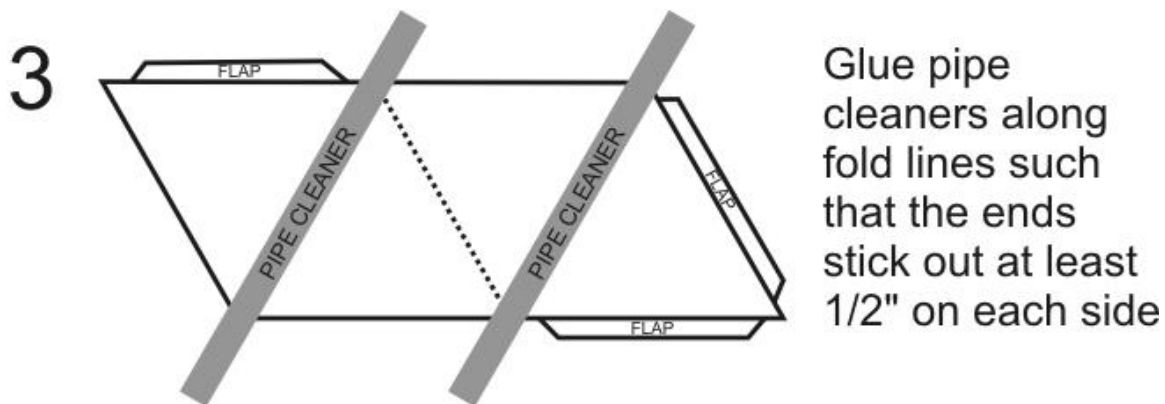
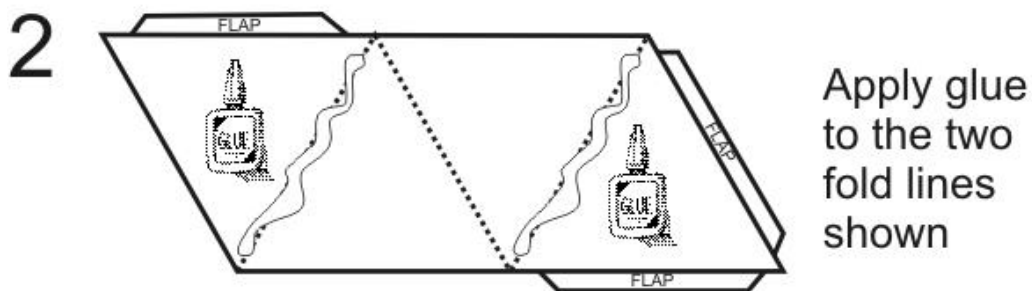
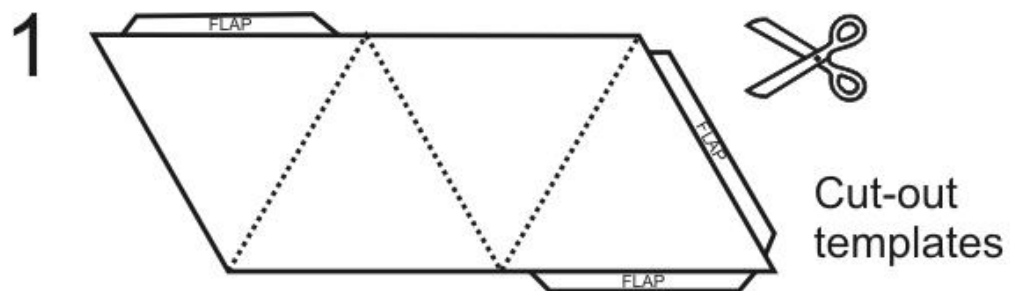

Is this a potentially stable mineral? Explain

If you were to continue to build on to this model, is there an obvious direction in which the crystal lattice would preferentially grow? What does this suggest with respect to the general shape that the crystal would develop as it grew?

Now start to twist and pull the model apart. Is there an obvious direction in which the crystal lattice preferentially broke? What does this suggest with respect to the general shape that the mineral would develop as it broke (*i.e.*, would there be cleavage or fracture)?

B. Ring Silicates

In ring tetrahedra silicates (e.g., tourmaline, beryl) neighboring silica tetrahedra link together in a chain that closes on itself to form rings. The remaining charge is balanced by bonding with cations. Neighboring rings can be linked together by sharing cations. Use the page labeled "Ring Silicates" as a guide in building your model.

At each table, each group will build a chain with six tetrahedra and no beads. When both groups are done, join the two models together using the bonds on the vertical apices (*i.e.*, the two sets will share three beads).

If you were to continue to build on to this model, is there an obvious direction in which the crystal lattice would preferentially grow? What does this suggest with respect to the general shape that the crystal would develop as it grew?

Now start to twist and pull the model apart. Is there an obvious direction in which the crystal lattice preferentially broke? What does this suggest with respect to the general shape that the mineral would develop as it broke (*i.e.*, would there be cleavage or fracture)? If there is cleavage, what shape would the fragments likely exhibit?

C. Single-Chain Silicates

In single-chain silicates (e.g., pyroxenes) neighboring silica tetrahedra link together in simple chains. The remaining charge is balanced by bonding with cations to the sides. Neighboring chains can be linked together by sharing cations. Use the page labeled "Single Chain Silicates" as a guide in building your model.

At tables 1 and 2, one group will build Chain 1 and the other group will build Chain 2, each with six tetrahedra and three beads. At tables 3 and 4, one group will build Chain 3 with six tetrahedra and three beads, and the other group will build Chain 4, with six tetrahedra and no beads.

If you were to continue to build on to this model, is there an obvious direction in which the crystal lattice would preferentially grow? What does this suggest with respect to the general shape that the crystal would develop as it grew?

When all groups are done, connect the two chains together at each table. Then have Tables 1 and 3, and Tables 2 and 4 join their models together.

Now start to twist and pull the model apart. Is there an obvious direction in which the crystal lattice preferentially broke? What does this suggest with respect to the general shape that the mineral would develop as it broke (*i.e.*, would there be cleavage or fracture)? If there is cleavage, what shape would the fragments likely exhibit?

D. Double-Chain Silicates

In double-chain silicates (e.g., amphiboles) neighboring silica tetrahedra link together in simple chains, and tetrahedra in paired chains bond together to form a wider chain. The remaining charge is balanced by bonding with cations to the sides. Neighboring double chains can be linked together by sharing cations. Use the page labeled "Double Chain Silicates" as a guide in building your model.

At tables 1 and 2, one group will build Chain 1 and the other group will build Chain 2, each with six tetrahedra and no beads. At tables 3 and 4, one group will build Chain 3, and the other group will build Chain 4, each with six tetrahedra and no beads. At each table, join the two chains together to form double chains.

If you were to continue to build on to this model, is there an obvious direction in which the crystal lattice would preferentially grow? What does this suggest with respect to the general shape that the crystal would develop as it grew?

Have Tables 1 and 3, and Tables 2 and 4 join their models together with 3 beads between them.

Now start to twist and pull the model apart. Is there an obvious direction in which the crystal lattice preferentially broke? What does this suggest with respect to the general shape that the mineral would develop as it broke (*i.e.*, would there be cleavage or fracture)? If there is cleavage, what shape would the fragments likely exhibit?

E. Sheet Silicates

In sheet silicates (e.g., muscovite, biotite) each silica tetrahedra shares oxygens with three neighboring tetrahedra within a plane. The remaining charge is balanced by bonding with cations on the upper surface. Neighboring sheets can be linked together by sharing cations. Use the page labeled "Sheet Silicates" as a guide in building your model.

Have each table collect (and possibly repair) their double chains from the double-chain experiment. Join the double chains from tables 1 and 2. Tables 3 and 4 will create their own sheet by joining their pair of double chains, but also add beads to each of the unbonded apices on the upper surface of the sheet. . one group will build Chain 1 and the other group will build Chain 2, each with six tetrahedra

If you were to continue to build on to this model, is there an obvious direction in which the crystal lattice would preferentially grow? What does this suggest with respect to the general shape that the crystal would develop as it grew?

Have Tables 1 and 3, and Tables 2 and 4 join their models together.

Now start to twist and pull the model apart. Is there an obvious direction in which the crystal lattice preferentially broke? What does this suggest with respect to the general shape that the mineral would develop as it broke (*i.e.*, would there be cleavage or fracture)? If there is cleavage, what shape would the fragments likely exhibit?

F. Sheet Silicates

In network silicates (e.g., quartz, feldspar) silica tetrahedra share oxygens with four neighboring tetrahedra in a three-dimensional network. If there is a remaining charge, it is balanced by bonding with cations. Use the page labeled "Network Silicates" as a guide in building your model.

Have each pair of tables collect (and possibly repair) their sheets from the sheet silicate experiment. Join the two sheets to form a network

If you were to continue to build on to this model, is there an obvious direction in which the crystal lattice would preferentially grow? What does this suggest with respect to the general shape that the crystal would develop as it grew?

Now start to twist and pull the model apart. Is there an obvious direction in which the crystal lattice preferentially broke? What does this suggest with respect to the general shape that the mineral would develop as it broke (*i.e.*, would there be cleavage or fracture)? If there is cleavage, what shape would the fragments likely exhibit?

Isolated Tetrahedra Silicates

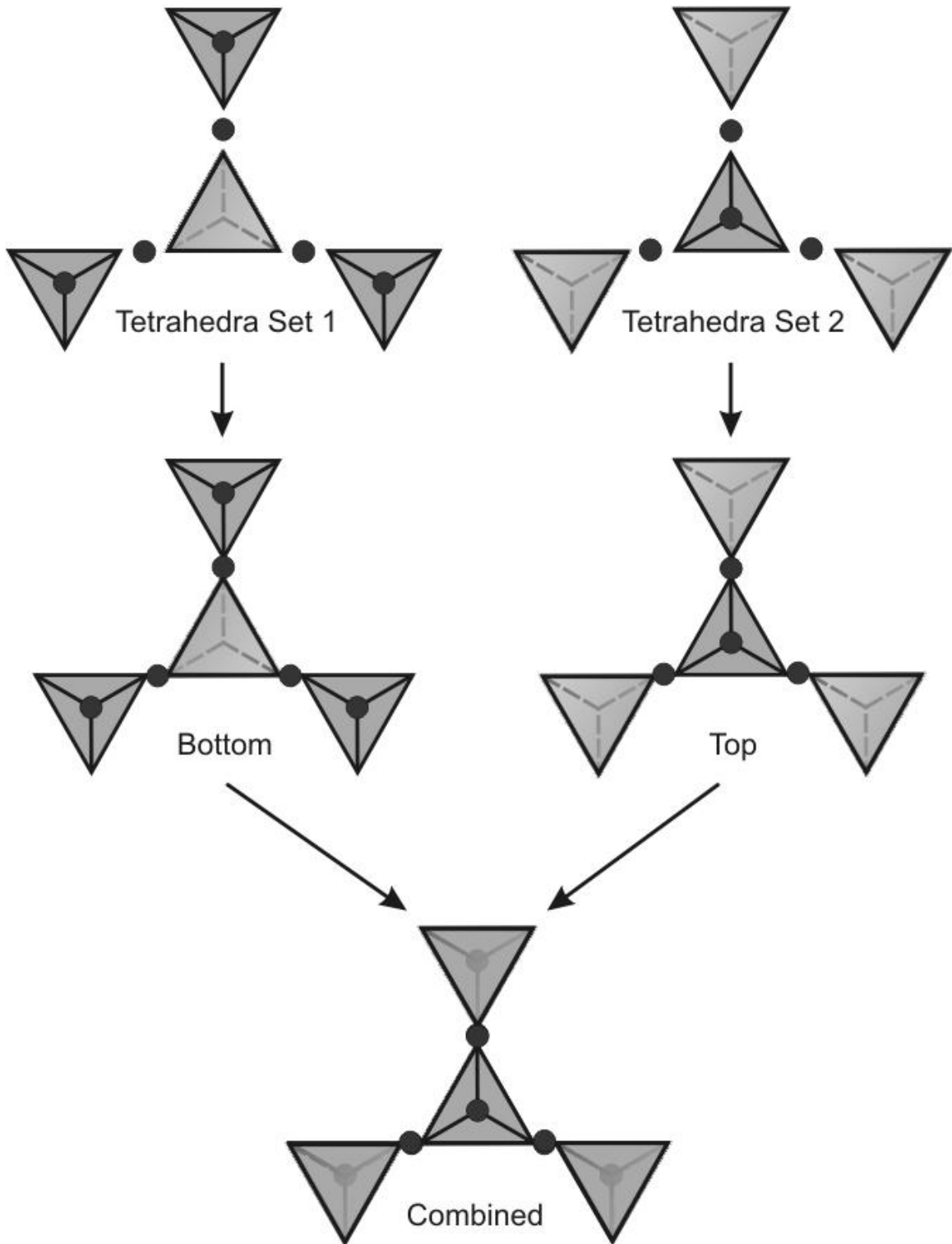

Ring Silicates

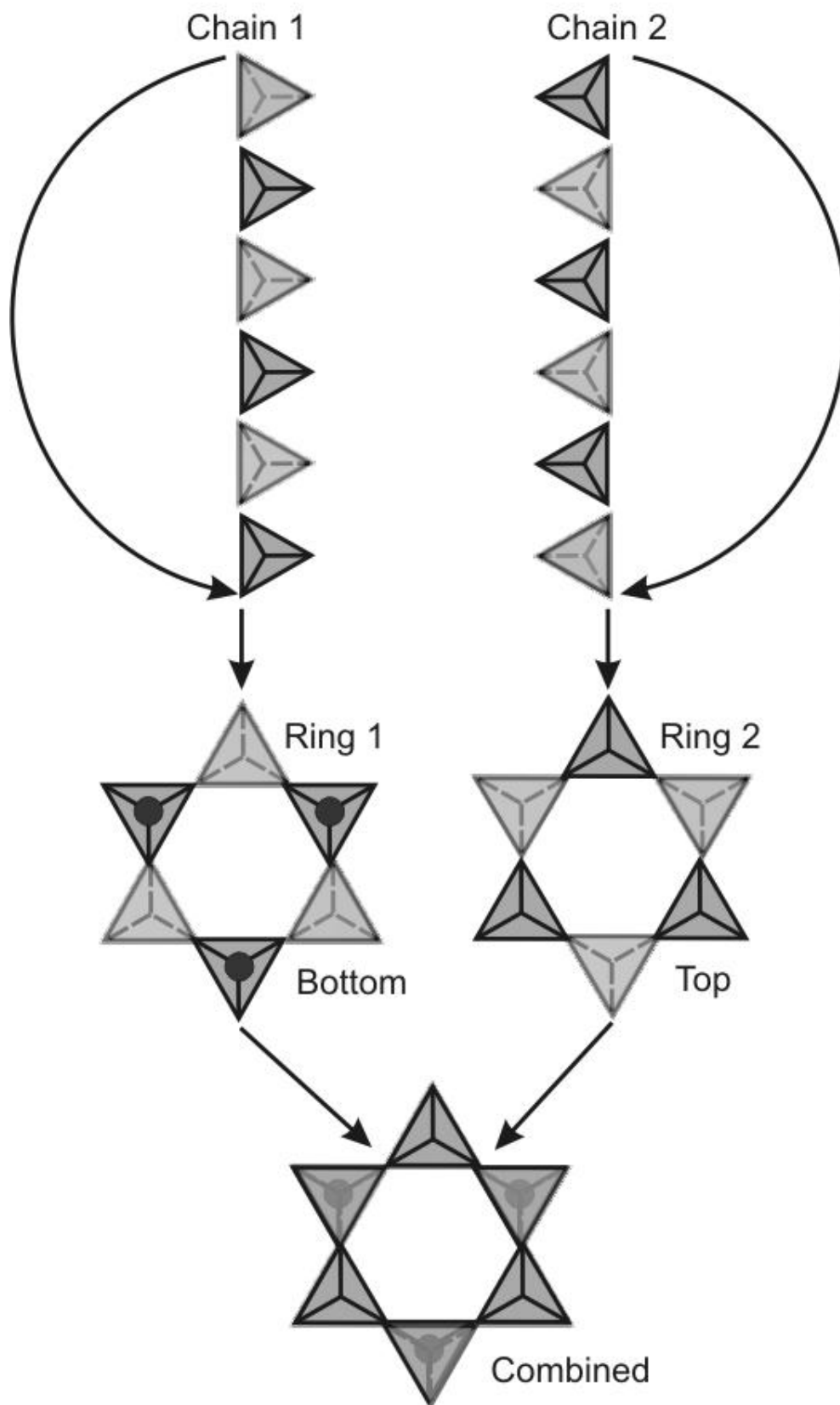

Single Chain Silicates

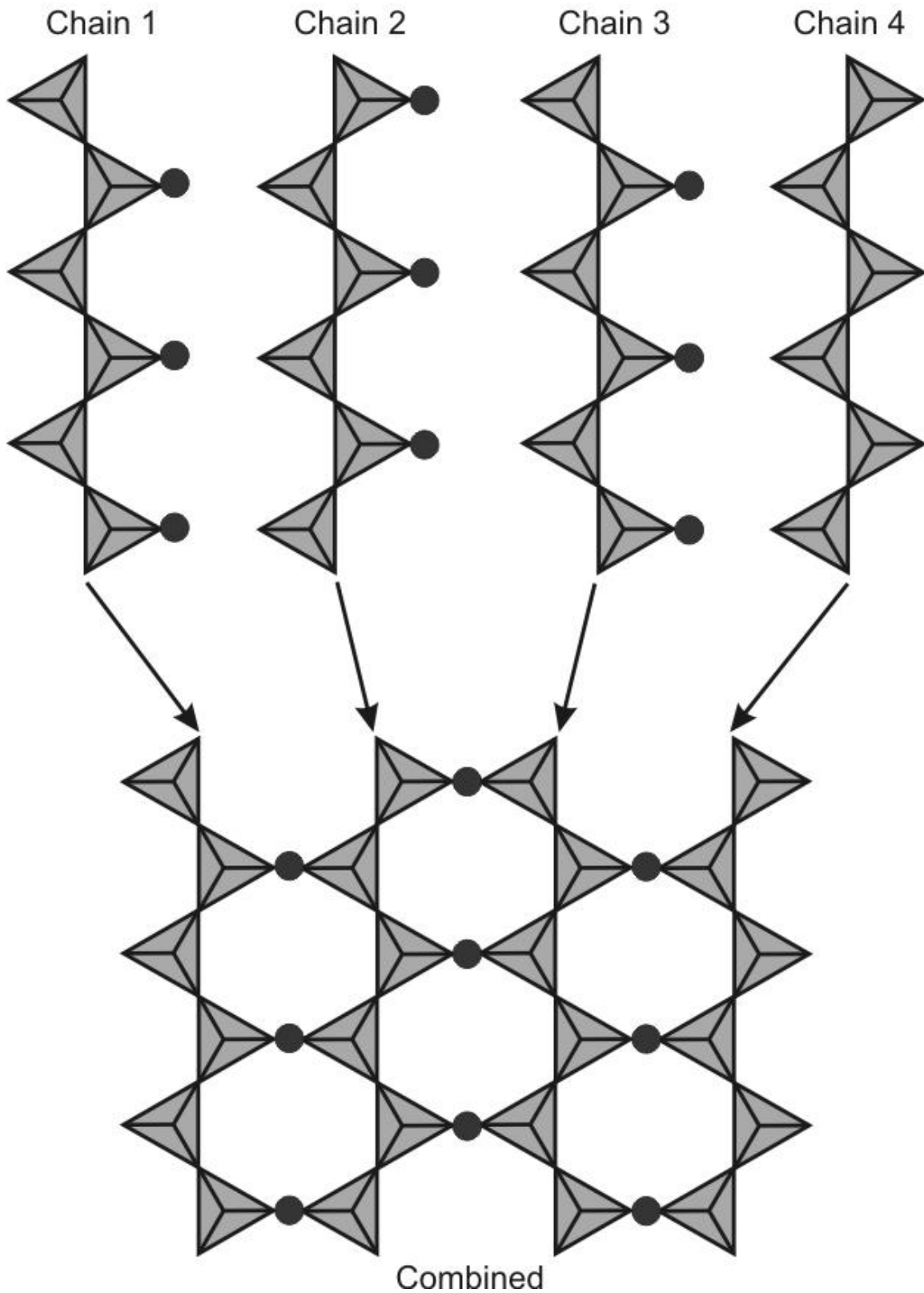

Double Chain Silicates

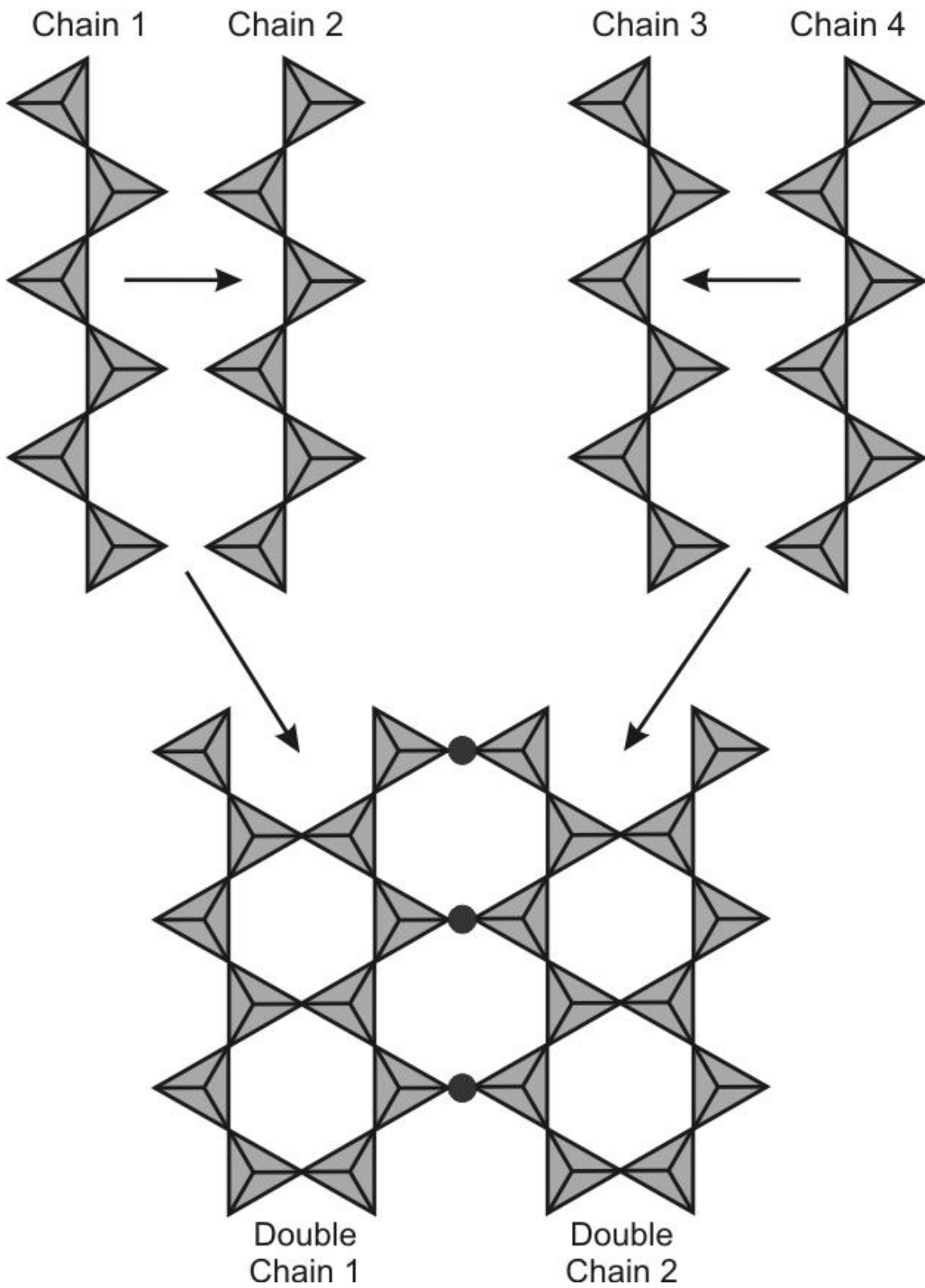

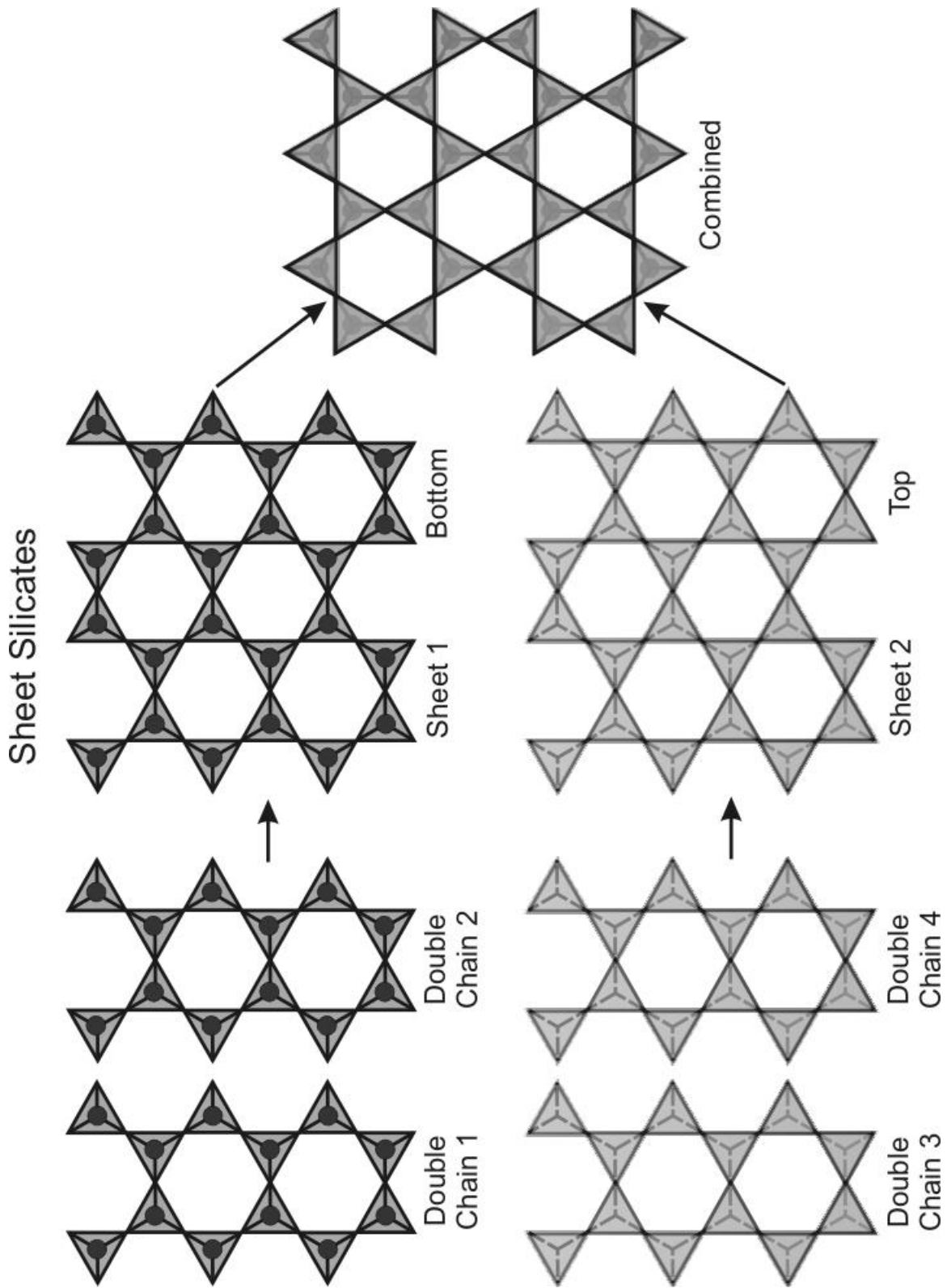

Network Silicates

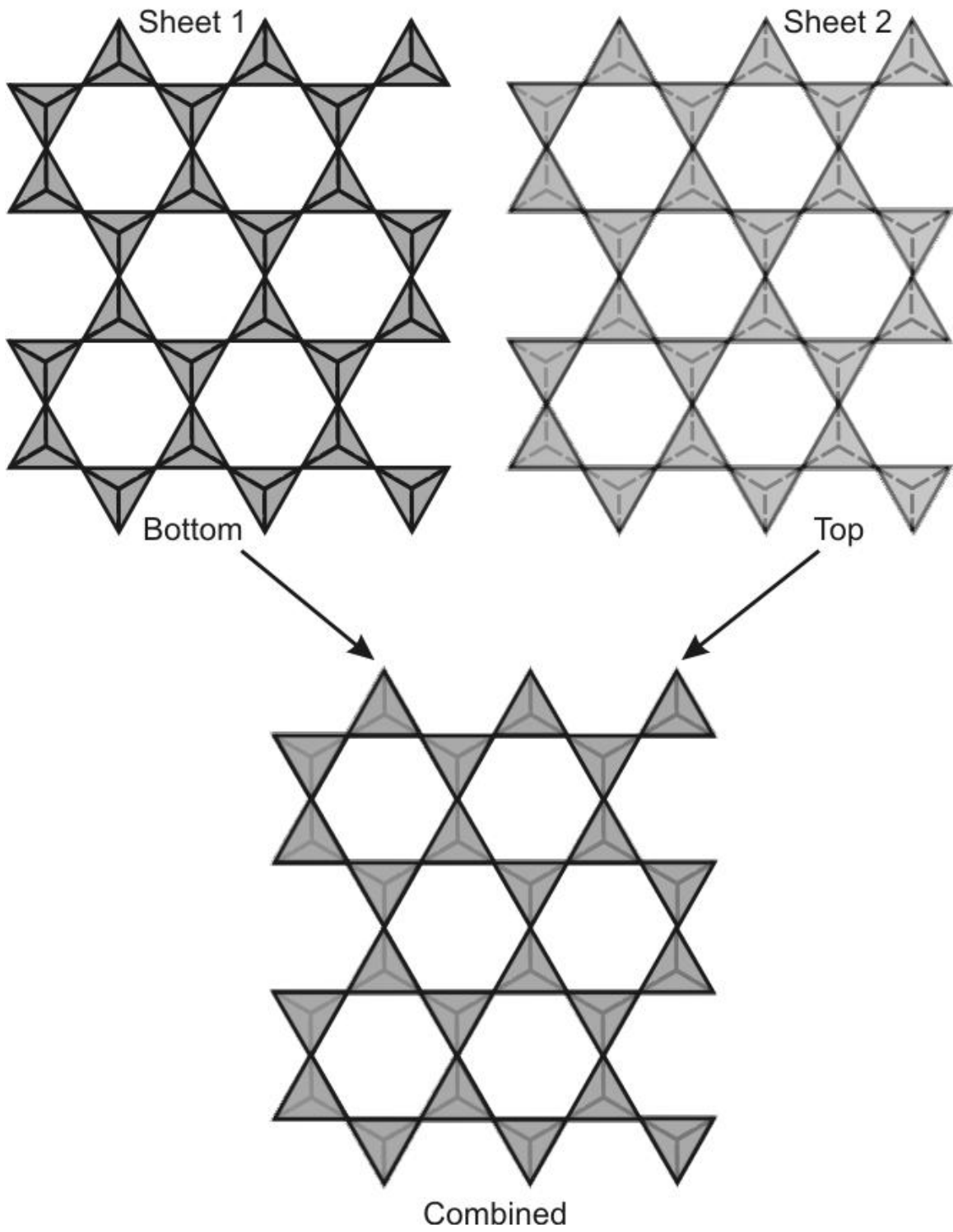

Template for Three Tetrahedra

